

D21-784

AU

EX

D2676

OR

D 023,937

DESIGN.

B. BARK.
BILLIARD TABLE.

No. 23,937.

Patented Jan. 1, 1895.

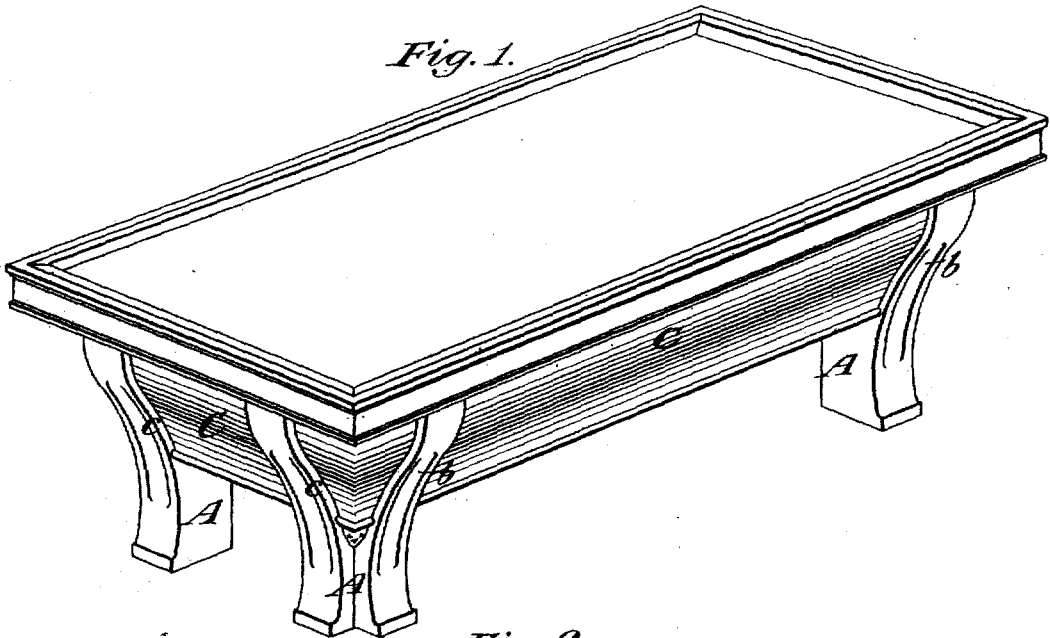

Fig. 1.

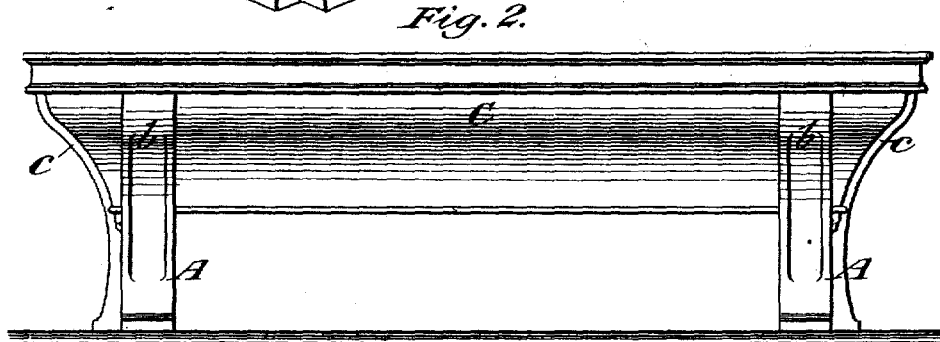

Fig. 2.

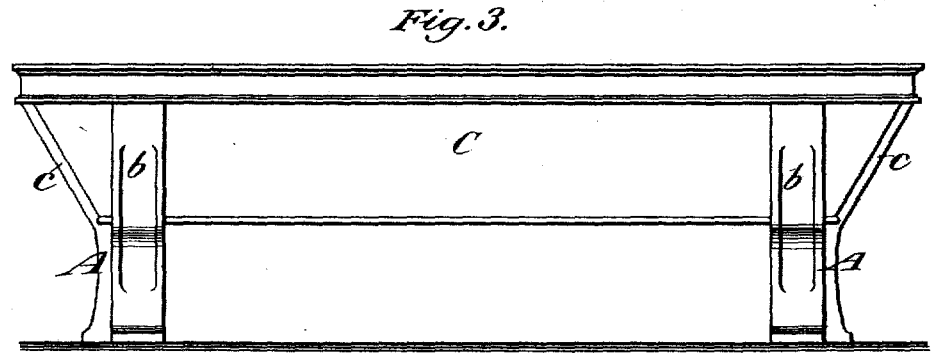

Fig. 3.

Witnesses:

N. H. Hayward
Chas. E. Cuyler

Inventor
Burger Bark
By Attorney
P. N. McIntire

UNITED STATES PATENT OFFICE.

BIRGER BARK, OF CHICAGO, ILLINOIS, ASSIGNOR TO THE BRUNSWICK-BALKE-COLLENDER COMPANY, OF SAME PLACE.

DESIGN FOR A BILLIARD-TABLE.

SPECIFICATION forming part of Design No. 23,937, dated January 1, 1895.

Application filed August 26, 1893. Serial No. 484,067. Term of patent 14 years.

To all whom it may concern:

Be it known that I, BIRGER BARK, a citizen of the United States, residing at Chicago, in the county of Cook and State of Illinois, have
5 invented and produced a new and original Design for Billiard-Tables, of which the following is a specification, reference being had to the accompanying drawings, forming part thereof.

10 My invention relates to billiard tables, and more especially to that type (which is now almost solely used) in which the sides of the body portion of the table slope, or incline, inwardly, or toward the center of the table, as
15 they descend from the cushion-rails.

Heretofore tables of various designs have been made; but in all the patterns I know of, the legs have constituted members, of the concrete design, that were located wholly below the body-portion of the table, and, hence,
20 no part of any leg has formed any portion of the design of the table at any point above the level of the lowermost portion of the table body, *i. e.*, that part of the table comprising the four "broad-rails," or sides of the
25 table.

The essential point of novelty, or characteristic feature of my new design lies in upward extensions of portions of each leg of the table, so that these portions of the legs are combined with the broad-rails, to form members of the design of that portion of the table called the body-portion, and give to the entire table a very novel and unique appearance.

35 In the accompanying drawings in which I have shown two modifications of my design, Figure 1 is a perspective view and Fig. 2, is a side elevation of a table embodying my invention, and of that type in which the broad-rails each present a surface composed of two reverse curves, *i. e.*, what is commonly called the ogee shape of body; while Fig. 3 is a side view of what is known as a plain bevel table, embodying my new design.

45 In each type of table it will be seen that each leg A is made with laterally projecting portions, or cheek-pieces, *b, c*, that (unlike the main body and table-supporting portion of the leg) extend clear up to the lower side of the cushion rails; or, in other words clear
50 up to a horizontal plane coincident with the

plane in which lie the upper edges of the broad-rails, or sides, C of the table. Each of these projecting portions, or cheek-pieces, *b* and *c*, of each leg, from a point coincident with the plane, or level, of the lower edges of the broad-rails C, up to its topmost point, corresponds in profile, or side view, with the profile, or cross-sectional shape, of that broad-rail C of the table, the end of which is contiguous to each of said cheek-pieces; so that, in the case of a table having ogee broad-rails (such as seen at Figs. 1 and 2), the profile of each cheek-piece *b* and *c* is an ogee, the lines of which are parallel with those of the broad-rail ogee; while in the case of a plane bevel table, such as shown at Fig. 3, the profile of each of the parts *b* and *c* of each leg, is a plane bevel that runs parallel with the bevel surface of that broad rail C, the end of which is contiguous to such cheek-piece.

In the cases shown each of the (duplicate) parts *b* and *c* of each leg presents a nearly flat surface crosswise (or in cross-section) and somewhat resembles a sort of pilaster, though its face, as above explained, runs nearly vertically from the base of the leg up to the lower edge of the table body, from whence it extends upward and at the same time outward, in a form corresponding to the configuration of the body of the table.

It will be understood, of course, that in carrying into effect my invention in cases in which the broad-rails are, for instance, concave, in profile, the upper parts of the leg portions *b c* will have a concave profile; and where the broad-rails may have convex surfaces, these portions *b* and *c* of the legs will have convex profiles to correspond to such shaped broad-rails; and so on, with reference to variously shaped table sides, will these parts *b* and *c* be correspondingly varied in profile to match the profile, or cross-sectional shape, of the broad-rail of the table.

Thus, it will be seen, my design may be embodied in tables of various shapes; the characteristic feature, (under all modifications of shape in the table) being the presence, in the leg member of the table, of parts *b* and *c*, which extend from the floor (or base of the leg) up to the top of the table body, and that conform in profile to the profile of

each broad-rail, or correspond in profile to the configuration of the body portion of the table.

5 What I therefore claim, broadly, as my new design is—

10 A design of billiard table comprising the characteristic feature of appearance resulting from the presence of the laterally projecting portions *b* and *c* of the legs, that extend clear up to the top of the table body and

correspond, in profile, to the shape of the body-portion of the table; as hereinbefore set forth and as shown in the drawings.

In witness whereof I have hereunto set my hand this 21st day of January, 1993.

BIRGER BARK.

In presence of—

A. W. WILLIAMSON,
B. E. BENSINGER.